

evOLUTION®

www.evolutionbuild.com



Registered Design, Patent Pending 1101605.2.

DWP1000 DIRTY WATER PUMP

ORIGINAL MANUAL

Please read instructions before operating this tool

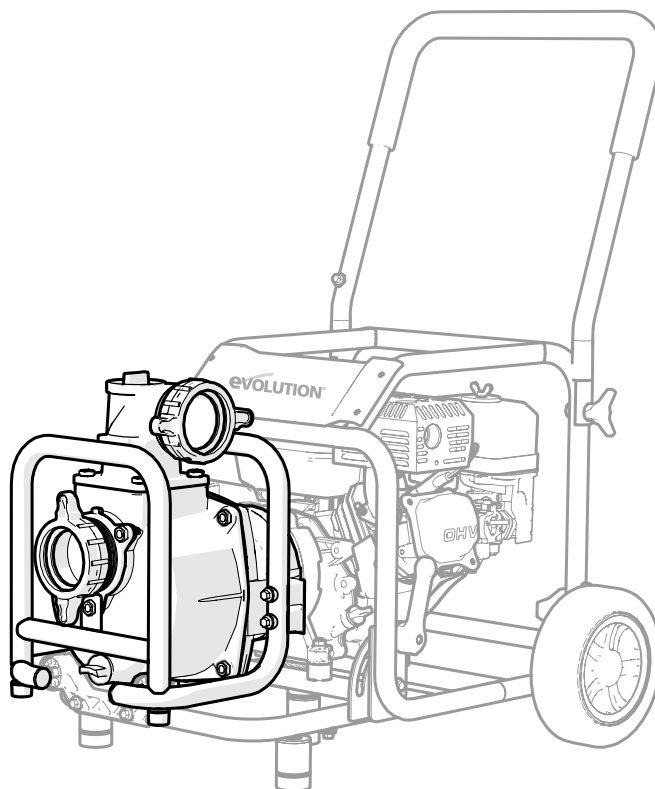

CZ

DA

DE

EL

ES

FI

FR

GB

IT

NL

NO

PL

PT

RU

SK

SV

CONNECT OUTPUT

QUICK REFERENCE GUIDE

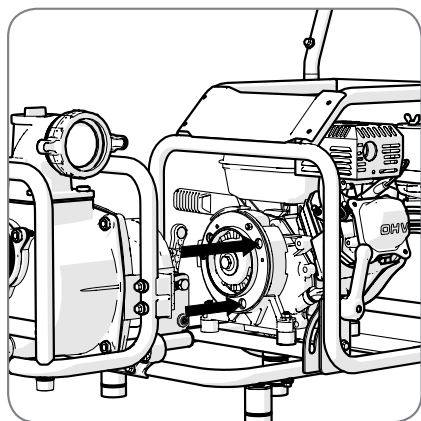

STEP 1...
LINE-UP 3 LOCATING PINS.
AS ARROWS INDICATE

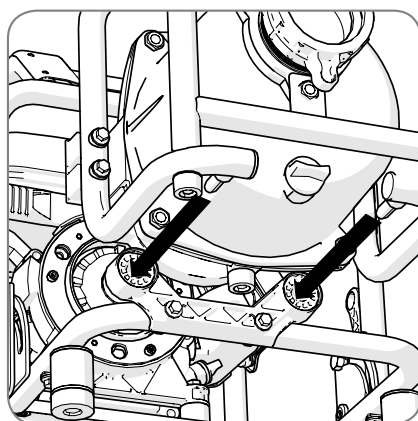

STEP 2...
LINE-UP 2 REAR STABILISER PINS.
AS ARROWS INDICATE

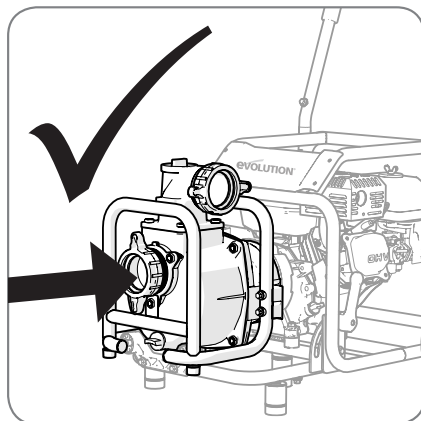

STEP 3...
APPLY GENTLE HORIZONTAL PRESSURE
WITH AN OPEN-HANDED FLAT-PALM.
AS ARROW INDICATES AND LOCK-IN

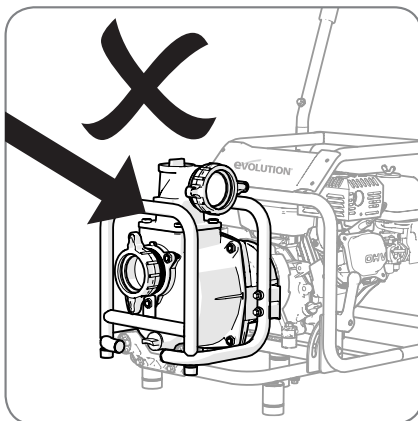

DO NOT...
APPLY SEVERE DIAGONAL DOWN-WARD
PRESSURE AS ARROW INDICATES. DOING
SO MAY DAMAGE THE EVO-SYSTEM!



SEEING IS BELIEVING!

Download a FREE QR READER APP
and scan the QR CODE (below).

Instantly watch the **HD Evo-System Video** on your Smart Phone.

Make sure the HD setting is on.

If you don't have a Smart Phone, you can also watch all Evolution's videos online.



CZ

DA

DE

EL

ES

FI

FR

GB

IT

NL

NO

PL

PT

RU

SK

SV

TABLE OF CONTENTS

| | |
|---|------------|
| EC - Declaration of Conformity | 118 |
| Important Information | 119 |
| Evolution Limited Guarantee | 119 |
| General Safety Rules | 119 |
| Engine Driven Water Pumps | 121 |
| Additional Specific Safety Rules | 121 |
| Symbols & Labels | 122 |
| Specifications | 122 |
| Machine Overview | 123 |
| Assembly | 125 |
| Operation | 127 |
| Maintenance | 129 |
| Environmental Protection | 129 |

NOTICE:

A parts diagram can be downloaded from
www.evolutionpowertools.co.uk/evosystem.html

EC - DECLARATION OF CONFORMITY**We, manufacturer and importer**

Evolution Power Tools Ltd.
Venture One
Sheffield
S20 3FR

Declare that the product;
Evolution DWP1000 Dirty Water Pump

Part numbers:
DWP1000

Complies with the essential requirements of
the following European Directives:

89/336/EEC – EMC Directive
2006/95/EC – Low Voltage Directive
98/37/EEC - Machinery Directive
2000/14/EC – Noise Directive

**The following standards
have been applied:**

EN 809/A1: 2009
EN ISO 1498: 2009

Authorised by

**Mr Matthew J Gavins**

Managing Director
1 September 2011

**All documentation is held on file at the
above address and is available, on request
for review.**

IMPORTANT

Please read these operating and safety instructions carefully and completely. For your own safety, if you are uncertain about any aspect of using this equipment please access the relevant Technical Helpline, the number of which can be found on the Evolution Power Tools website. We operate several Helplines throughout our worldwide organization, but Technical help is also available from your supplier.

WEB

www.evolutionpowertools.com

EMAIL

enquiries@evolutionpowertools.com

EVOLUTION DWP1000 WATER PUMP

Congratulations on your purchase of an Evolution Power Tools **DWP1000 WATER PUMP**. Please complete your product registration online to validate your machine's warranty period and ensure prompt service if needed. We sincerely thank you for selecting a product from Evolution Power Tools.

EVOLUTION LIMITED GUARANTEE

Evolution Power Tools reserves the right to make improvements and modifications to the product design without prior notice. Please refer to the guarantee registration leaflet and/or the packaging for details of the terms and conditions of the guarantee.

Evolution Power Tools will, within the guarantee period, and from the original date of purchase, repair or replace any goods found to be defective in materials or workmanship. This guarantee is void if the tool being returned has been used beyond the recommendations in the Instruction Manual or if the machine has been damaged by accident, neglect, or improper service.

This guarantee does not apply to machines and/or components which have been altered, changed, or modified in any way, or subjected to use beyond recommended capacities and specifications. Electrical components

are subject to respective manufacturers' warranties. All goods returned defective shall be returned prepaid freight to Evolution Power Tools. Evolution Power Tools reserves the right to optionally repair or replace it with the same or equivalent item.

There is no warranty – written or verbal – for consumable accessories such as (following list not exhaustive) blades, cutters, drills, chisels or paddles etc. In no event shall Evolution Power Tools be liable for loss or damage resulting directly or indirectly from the use of our merchandise or from any other cause. Evolution Power Tools is not liable for any costs incurred on such goods or consequential damages. No officer, employee or agent of Evolution Power Tools is authorized to make oral representations of fitness or to waive any of the foregoing terms of sale and none shall be binding on Evolution Power Tools.

Questions relating to this limited guarantee should be directed to the company's head office, or call the appropriate Helpline number.

GENERAL SAFETY RULES

WARNING: Read all instructions. Failure to follow all instructions listed below may result in electric shock, fire and/or serious injury.

SAVE THESE INSTRUCTIONS

1. Work area safety

a. Keep work area clean and well lit.

Cluttered and dark areas invite accidents.

b. Do not operate power tools in explosive atmospheres, such as in the presence of flammable liquids, gases or dust. Power tools create sparks which may ignite the dust or fumes.

c. Keep children and bystanders away while operating a power tool.

Distractions can cause you to lose control.

2. Electrical safety

a. Power tool plugs must match the outlet. Never modify the plug in any way.

Do not use any adapter plugs with earthed (grounded) power tools.

Unmodified plugs and matching outlets will reduce risk of electric shock.

b. Avoid body contact with earthed or grounded surfaces such as pipes, radiators, ranges and refrigerators. There is an increased risk of electric shock if your body is earthed or grounded.

c. Do not expose power tools to rain or wet conditions. Water entering a power tool will increase the risk of electric shock.

d. Do not abuse the cord. Never use the cord for carrying, pulling or unplugging the power tool. Keep cord away from heat, oil, sharp edges or moving parts. Damaged or entangled cords increase the risk of electric shock.

e. When operating a power tool outdoors, use an extension cord suitable for outdoor use. Use of a cord suitable for outdoor use reduces the risk of electric shock.

f. If operating a power tool in a damp location is unavoidable, use a residual current device (RCD) protected supply. Use of an RCD reduces the risk of electric shock.

3. Personal safety

a. Stay alert, watch what you are doing and use common sense when operating a power tool. Do not use a power tool while you are tired or under the influence of drugs, alcohol or medication. A moment of inattention while operating power tools may result in serious personal injury.

b. Use safety equipment. Always wear eye protection. Safety equipment such as dust mask, non-skid safety shoes, hard hat, or hearing protection used for appropriate conditions will reduce personal injuries.

c. Avoid accidental starting. Ensure the switch is in the off-position before plugging in. Carrying power tools with your finger on the switch or plugging in power tools that have the switch on invites accidents.

d. Remove any adjusting key or spanner before turning the power tool on. A spanner or a key left attached to a rotating part of the power tool may result in personal injury.

e. Do not overreach. Keep proper footing and balance at all times. This enables better control of the power tool in unexpected situations.

f. Dress properly. Do not wear loose clothing or jewellery. Keep your hair, clothing and gloves away from moving parts. Loose clothes, jewellery or long hair can be caught in moving parts.

g. If devices are provided for the connection

of dust extraction and collection facilities, ensure these are connected and properly used. Use of these devices can reduce dust related hazards.

4. Power tool use and care

a. Do not force the power tool. Use the correct power tool for your application.

The correct power tool will do the job better and safer when used at the rate for which it was designed.

b. Do not use the power tool if the switch does not turn it on and off. Any power tool that cannot be controlled with the switch is dangerous and must be repaired.

c. Disconnect the plug from the power source before making any adjustments, changing accessories, or storing power tools. Such preventive safety measures reduce the risk of starting the power tool accidentally.

d. Store idle power tools out of the reach of children and do not allow persons unfamiliar with the power tool or these instructions to operate the power tool.

Power tools are dangerous in the hands of untrained users.

e. Maintain power tools. Check for misalignment or binding of moving parts, breakage of parts and any other condition that may affect the power tools operation. If damaged, have the power tool repaired before use. Many accidents are caused by poorly maintained power tools.

f. Keep cutting tools sharp and clean. Properly maintained cutting tools with sharp cutting edges are less likely to bind and are easier to control.

g. Use the power tool, accessories and tool bits etc., in accordance with these instructions and in the manner intended for the particular type of power tool, taking into account the working conditions and the work to be performed.

Use of the power tool for operations different from intended could result in a hazardous situation.

5. Service

Have your power tool serviced by a qualified repair person using only genuine replacement parts.

This will ensure that the safety of the power tool is properly maintained.

SAFETY INSTRUCTIONS FOR ENGINE DRIVEN WATER PUMPS

- a. Petrol or diesel powered engines must never be used in unventilated closed spaces.** The exhaust fumes produced are highly toxic and can cause 'Carbon Monoxide Poisoning' which will cause drowsiness and ultimately death. It is only permissible to run a petrol engine indoors if the building can be very well ventilated and the exhaust fumes can be captured and ducted to the outside through an exhaust extraction/scavenger system
- b. The Engine/Water Pump should be positioned on a firm level surface.** The wheels should be locked, so that the engine cannot move during operation.
- c. The engine should not be run at speeds that exceed the maximum speed on the rating plate.** Operating an engine at excessive speeds increases the likelihood of component failure and consequent accidents.
- d. Do not tamper with components that regulate the engines speed.** You may alter the factory set running parameters.
- e. Use only the type of fuel listed in the Evo-System Evo200 Engine Instruction Manual.** Using fuel with an octane rating less than that specified can lead to excessive engine wear and premature engine failure.
- f. Keep the area around the engine clear, clean and tidy.** Never allow any combustible material (timber, plastic, cardboard, canvas etc) near a running engine.
- g. Do not use in or near to potentially explosive atmospheres.** Dust laden atmospheres as can be found in some industrial buildings (Flour Mills, Timber Mills) have an explosive potential.
- h. Regularly check the fuel system for leaks. Hoses and unions should be checked for deterioration or chafing.** Check the fuel tank for damage or for a poorly fitting or worn fuel cap. Any defects must be rectified before the engine is used.
- i. Always stop the engine and allow it to cool down before refuelling.** Try to avoid any fuel spillage (often caused by 'overfilling' the tank) and clean up any spilt fuel immediately. The application of dry sand is an effective way of neutralising fuel spills.
- j. Do not allow the engine to run out of fuel.** Surging of the engine as it uses

the last of the fuel could cause damage to connected equipment.

- k. When transporting the engine in a vehicle ensure that the fuel tap is turned off.** To minimise the risk of fuel spillage the engine should be secured by ropes etc to the load area of the vehicle so that it cannot move during transportation. The engine should be secured in as level an attitude as possible.
- l. For long term storage we recommend that the fuel system of the engine is drained.** During long term storage additives in modern fuels can precipitate from the fuel and block jets and valves in the fuel system.
- m. Store the machine in a secure and well ventilated area.** Unauthorised personnel should not have access to this machine.

ADDITIONAL SPECIFIC SAFETY RULES









- a. Position the pump carefully and ensure that it cannot move during operation.** It may be desirable to chock the wheels in addition to applying the wheel brake.
- b. Keep the immediate area around the pump clear.** Ensure that no combustible materials can come into contact with the engine.
- c. Always fit an inlet strainer to the inlet hose.** This will prevent large stones or other debris from being drawn up into the pump body and causing damage.
- d. Keep the inlet filter clean.** During operation the inlet filter could become blocked, restricting water flow and imposing additional strain on the engine.
- e. Position the water discharge (outlet pipe) well away from the pump.** Keep the pump and the engine as dry as possible.
- f. Do not use this equipment to pump petrol (or any other flammable liquids) or other corrosive liquids.** This pump is designed to pump Water Only.
- g. Never run the pump dry.** Always fill the pump (prime) with water before starting.
- h. Never direct the discharged water towards electrical equipment or wiring.** Water can severely damage electrical equipment can potentially pose a serious fire hazard.
- i. Always use at least 300mm of flexible hose to couple any rigid piping to the pump.** Coupling rigid piping directly to the pump can impose stresses and strains

beyond the pumps designed capacity.

j. Observe all safety rules for the operation of the engine as outlined in the relevant Instruction Manual. Observe particularly the refuelling procedures and safety rules.

SYMBOLS & LABELS

WARNING: Do not operate machine if warning and/or instruction labels are missing or damaged. Contact Evolution Power Tools for replacement labels.

| Symbol | Description |
|---|---|
|  | Read the Manual |
|  | Wear Safety Goggles |
|  | Wear Ear Protection |
|  | Wear Dust Protection |
|  | Warning |
|  | CAUTION: Hot exhaust Do not touch |
|  | CAUTION: This is a 4 stroke engine. Fill with unleaded petrol only. Do not fill with diesel oil. |
|  | Allow motor to cool before opening the fuel cap. The vapour is extremely flammable and may ignite on contact with a hot surface or flames. |

DWP1000 WATER PUMP SPECIFICATION

Inlet & Outlet Diameter: 75mm

Pump Lift: 28 metres

Suction Height: 8 metres

Flow Rate: 1000 Litres/min

Optional Accessories:
Suction Hose (Rigid)
Discharge Hose (Lay Flat)
Inlet Strainer

Weight: 10.7kg

Note: The Evo-System Engine Driven Water Pump is designed for pumping water. It will also pump water containing small solids in suspension (max grain structure 8mm).

It is not designed to pump slurry, sludge, sand or mud. The pump is fitted with an open impellor. A suction filter should always be used on the inlet hose to ensure that large stones or debris etc are not sucked up into the pump body. Damage can result if large particles are drawn into the pump body.

Machine Overview

General view of Water Pump connected to the Engine Unit.

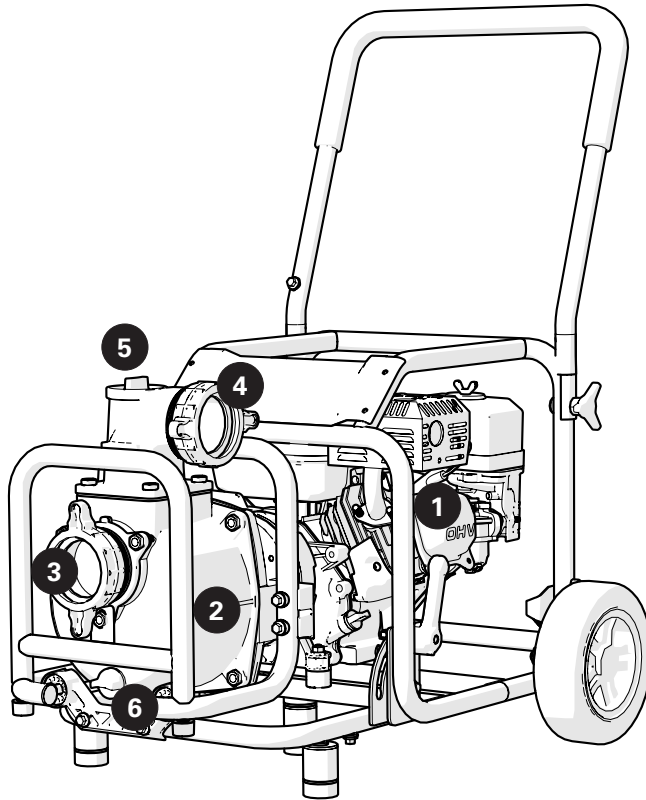

1. Evo-System Engine

2. DWP1000 Water Pump

3. Inlet Port

4. Outlet Port

5. Filler Plug

6. Drain Plug

Machine Overview

General view of Water Pump connected to the Engine Unit.

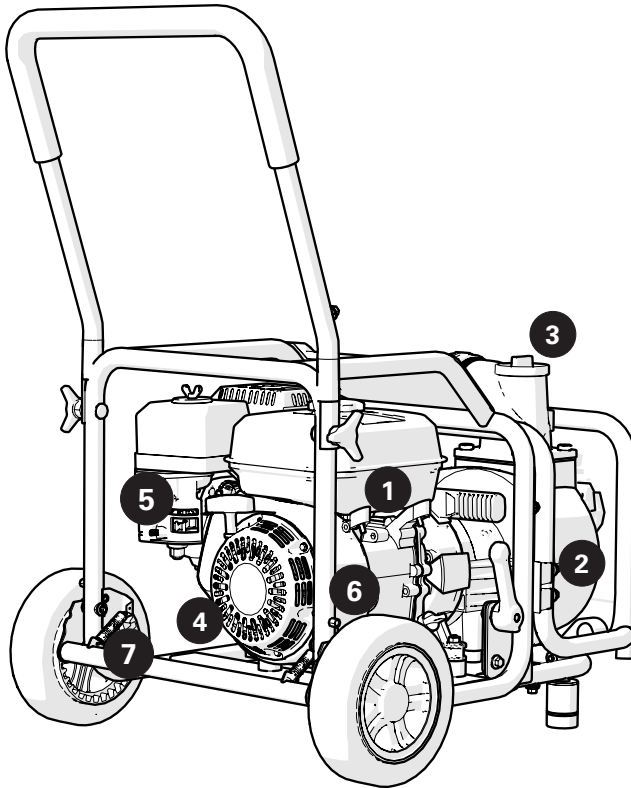

1. Evo-System Engine

2. DWP1000 Water Pump

3. Filler Plug

4. Pump Drain Plug

5. Fuel Tap Switch / Choke on/off

6. On/Off switch

7. Foot brake

ASSEMBLY

1. Connecting the DWP100 Water Pump to the Evo-System Engine

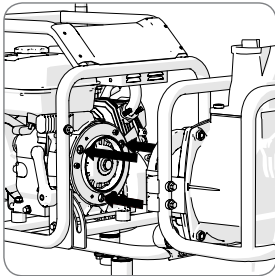

Fig 1a
(LH view of 3 locating pins)

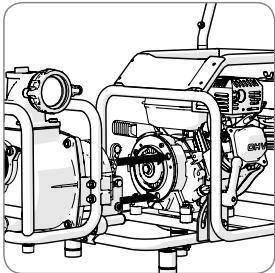

Fig 1b
(RH view of 3 locating pins)

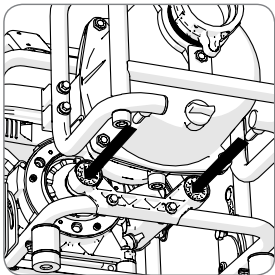

Fig 1c
(showing 2 rear stabiliser pins)

Note: Your Evolution Pump is designed to be connected to and powered by the Evo-System Engine. Do not try to connect this machine to any other power source. Your Evo-System Engine has a unique patented coupling that enables a variety of Evo-System accessories to be connected to and be driven by this machine.

This coupling is engineered to very fine tolerances and must be kept clean and free from dirt, debris etc.

A cover for coupling protection is provided with each accessory and should be used whenever the accessory is 'remote' from the engine.

If you experience difficulty in accessory connection, it could be because the accessory location pins, or the annuli of either the accessory or the engine are contaminated or damaged.

Preparing the Engine for accessory connection:

Note: The Evo-System Engine has a micro switch incorporated within the coupling design that senses when an accessory has been successfully attached to the machine. The engine will not start without an accessory being successfully connected. It cannot be run as a 'stand alone' machine.

- Lock the Transportation Wheels using the wheelbrake.
- Release the Accessory Mounting Frame by rotating the locking levers to their unlocked (down) position and push levers in.
- Deploy the Accessory Mounting Frame.
- Lock the frame into position by pulling out and returning the locking levers to their locked (upright) position.

Pump connection

Note: The Pump is equipped with 3 locating pins and 2 rear stabilising pins. The 3 locating pins lock into the 'Uncoupling'. The other 2 stabilising pins slide into the sockets in the Accessory Mounting Frame.

- Hold the accessory by its external frame and offer it up to the engine. Visually align the 3 locating pins (**Fig.1a & Fig.1b**) and 2 rear stabilising pins (**Fig.1c**). Enlist competent help if necessary.
- Holding onto a convenient part of the external engine frame can aid the operator achieving and maintaining alignment when connecting an accessory.
- Gently push the accessory into the engine. Keep the 3 locating pins and the 2 stabilising pins aligned with their respective docking positions. The internal coupling between the engine and the accessory will be made

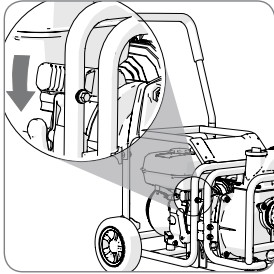

Fig 2

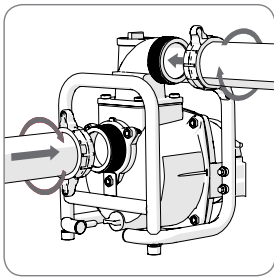

Fig 3

automatically. No component alignment or adjustments are necessary.

- Be gentle and patient, the coupling is precisely engineered and no great force is required to connect the accessories. Once the operator has mastered the 'technique', accessory connection will become straight forward.
- Firmly push the engine and accessory together until the 'click' of docking is heard. The Uni-coupling release lever will return to its neutral position. **(Fig. 2)**

2. Connecting the Hoses

Note: Hoses should be independently supported. They should not be carried by the pump.

- Check the integrity of the hoses. There must be no damage to either the inlet or discharge hose.
- Connect the hoses to the pump body using the hose clamps and gaskets supplied. **(Fig. 3)** Check that the gaskets are correctly seated.

Note: Any air leak in the inlet (suction) hose could prevent priming and reduce the flow rate of the pump.

- If using fixed steel pipework always ensure that the connection to the pump body is made with a piece of flexible hose at least 300mm long.
- Keep all pipes and hoses as short and straight as possible, and try to avoid sharp turns.
- Ensure that the discharged water has an adequate drainage channel.
- If any flexible hose is laid across a roadway or similar, protect the hose from vehicular traffic with wooden planking.
- A suction strainer should be attached to the end of the inlet hose. It is important to prevent large pieces of debris or stones etc from being drawn into the pump body and damaging the impellor.
- The inlet hose may need to be weighted down to keep it in position in the pond or excavation pit etc.

Note: If a vehicle were to run over an unprotected flexible hose, the instant crushing of the hose, and consequent stoppage of the water flow could cause 'hydraulic shock'. This could damage the pump and/or its fittings.

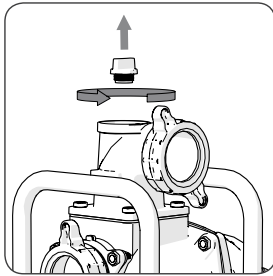

Fig 4

3. Check Valve

If the discharge hose has a vertical lift of more than 10 metres, we recommend that a check valve (not supplied) is installed in the hose near the pump. This will prevent potentially destructive water hammer occurring when the pump is shut down.

OPERATION

1. Siting the Equipment

Note: The Evo-System Engine with the pump attached should be sited with reference to the instructions given in the Evolution Engine Instruction Manual (SAFETY INSTRUCTIONS FOR EVO-SYSTEM ENGINE).

Site the equipment and check:

- The equipment is as level as possible.
- The wheel brake is applied.
- The surface is firm and stable.
- No combustible materials are close by.
- The area is well ventilated, and that there is no danger from the expelled exhaust gases.

Note: The Evo-System Engine is fitted with a low oil level shut down feature which protects the engine from damage due to lack of lubrication. This feature could be activated if the machine is sited on a slope of greater than 10°.

2. Initial Priming of the Pump

Note: The pump is self-priming only when the pump body is filled with water.

- Remove the filler plug from the top of the pump. (**Fig. 4**)
- Fill the pump fully with water. Do not leave any air gap.
- Replace the filler plug. Refilling is only necessary if the pump has been drained or the water supply has been lost.

Note: All water pumps can be 'temperamental' when priming. Initial priming can sometimes be assisted by temporarily restricting the output flow (the operator could place a foot on the outlet hose) until priming is achieved. Never allow the pump to run 'dry' for any prolonged period.

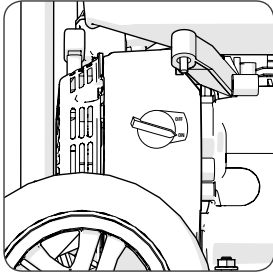

Fig 5

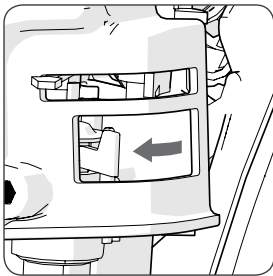

Fig 6

3. Starting the Evolution Evo-System Engine

The procedure for starting the engine can be found in the Instruction Manual for the Evolution Engine.

4. Pump Output

Note: Output of the pump is determined by the speed of the engine and by the length and elevation of the pipe runs.

5. Shutting Down

To shut down pumping operations:

- Stop the Engine by turning the ignition switch to the 'OFF' position. **(Fig. 5)**
- Close the fuel tap. **(Fig. 6)**

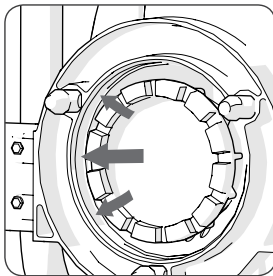

Fig 7 (arrows show inner wall of annular ring)

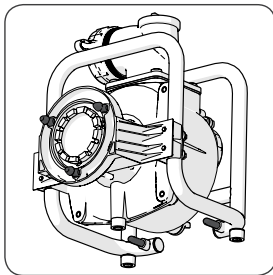

Fig 8 (3 locating pins & 2 stabilising pins highlighted)

MAINTENANCE

Note: The maintenance schedule for the Evolution Evo-System Engine can be found in the dedicated Instruction Manual.

- Keep the pump clean and regularly check the tightness of all bolts and fastenings.
- Keep the annular ring scrupulously clean and free from debris. **(Fig. 7)**
- Keep the 3 locating pins and 2 stabilising pins clean and occasionally lightly spray with a silicone oil based spray. **(Fig. 8)**
- Keep all Uni-coupling mating surfaces clean and free from dirt or debris.
- At every connection or disconnection check the accessory drive cog for dirt or debris contamination, particularly between the teeth. Clean and lubricate as per the instructions for the engine drive clutch (found in Engine Instruction Manual). Do not spray lubricant onto the 'drive cog'.
- If the pump has been used to pump salty or contaminated water of any kind, it should be thoroughly flushed with clean water (both the inside and the outside) as soon as possible after use. The pump body should be drained, allowed to dry and the drain plug replaced.
- Whenever the accessory is 'remote' from the engine the coupling protection cover (provided) should be used to protect the coupling.

LONG TERM STORAGE

We recommend that both hoses (water input and water output) are removed from the pump. Drain the pump body of any residual water by removing the drain plug. Store in a secure, dry location, covered by a clean cloth to prevent the ingress of dirt, debris etc.

ENVIRONMENTAL PROTECTION

Was electrical or mechanical products should not be disposed of with household waste. Please recycle where facilities exist. Check with your Local Authority or retailer for recycling advice.

DID YOU KNOW YOU CAN ALSO BUY...

ENGINE UNIT

- ✓ Wheel kit provides mobility.
- ✓ Folding handle for storage.
- ✓ Robust & durable steel frame.

• Power: 6.5hp, 4-Stroke • Power Take Off (PTO)
• Easy Recoil Start • Fuel Capacity: 3.1L • EV0200

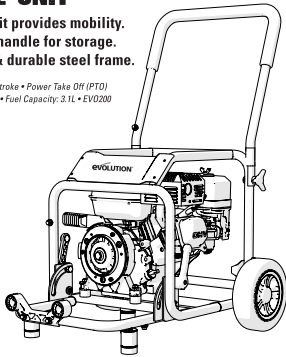

EVO-SYSTEM ENGINE

WATER PUMP

- ✓ Pumps 1000L per minute.
- ✓ Inlet filter prevents unwanted debris from entering the pump.

• Use With: 3" (75mm) Hose • Suction Height: 8m
• Pump Lift: 28m • DWP1000

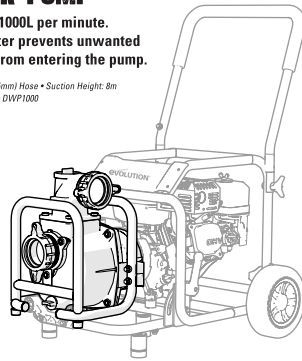

WATER PUMP OUTPUT

PRESSURE WASHER

- ✓ High quality brass pump.
- ✓ Includes lance with adjustable nozzle & hose.
- ✓ Built-in detergent system.

• Max. Flow Rate: 8L/min • Rated Pressure: 175bar
• Max. Pressure: 220bar • PW2000

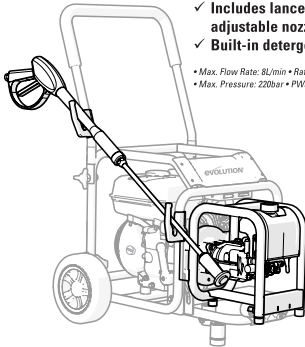

PRESSURE WASHER OUTPUT

GENERATOR

- ✓ Switchable voltages.
- ✓ Thermal cut-outs.
- ✓ Automatic voltage regulation.

• Power: 2400W (Continuous) • AC Output
• Sockets: 1 x 110V & 1 x 230V • GEN200

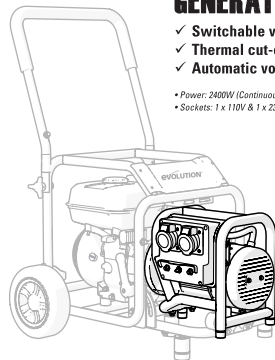

GENERATOR OUTPUT



Registered Design. Patent Pending 1101605.2.

...WITH MORE OUTPUTS AVAILABLE SOON!