

evOLUTION®

www.evolutionpowertools.com

S42MAG S28MAG

Original Instructions

S42MAG shown without guards fitted for illustrative purposes only.

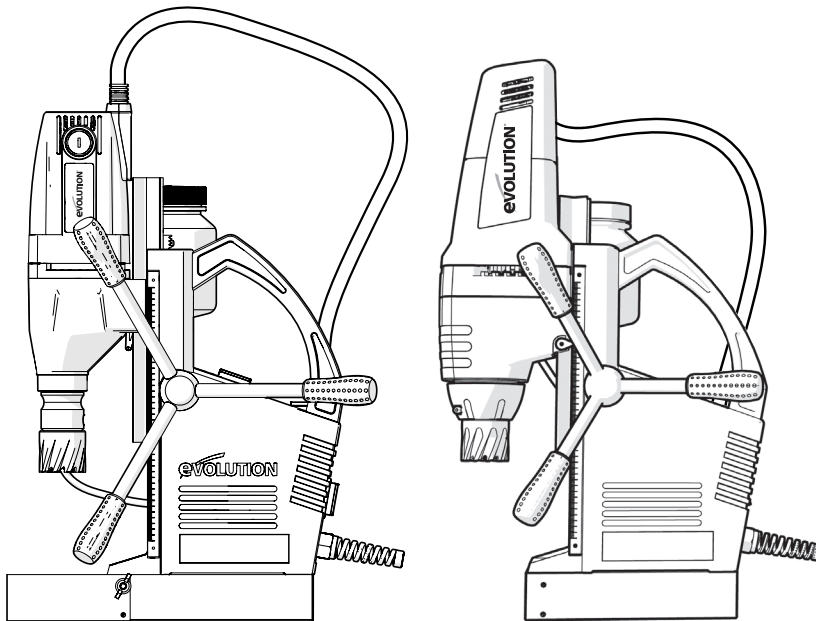

**THIS INSTRUCTION MANUAL WAS
ORIGINALLY WRITTEN IN ENGLISH.**

IMPORTANT

Please read these operating and safety instructions carefully and completely. For your own safety, if you are uncertain about any aspect of using this equipment please access the relevant Technical Helpline, the number of which can be found on the Evolution Power Tools website. We operate several Helplines throughout our worldwide organization, but Technical help is also available from your supplier.

WEB

www.evolutionpowertools.com/register

Congratulations on your purchase of an Evolution Power Tools Product. Please complete your product registration 'online' as explained in the A4 online guarantee registration leaflet included with this machine. You can also scan the QR code found on the A4 leaflet with a Smart Phone. This will enable you to validate your machine's guarantee period via Evolution's website by entering your details and thus ensure prompt service if ever needed. We sincerely thank you for selecting a product from Evolution Power Tools.

EVOLUTION LIMITED GUARANTEE.

Evolution Power Tools reserves the right to make improvements and modifications to the product design without prior notice.

Please refer to the guarantee registration leaflet and/or the packaging for details of the terms and conditions of the guarantee.

Evolution Power Tools will, within the guarantee period, and from the original date of purchase, repair or replace any goods found to be defective in materials or workmanship. This guarantee is void if the tool being returned has been used beyond the recommendations in the Instruction Manual or if the machine has been damaged by accident, neglect, or improper service. This guarantee does not apply to machines and / or components which have been altered, changed, or modified in any way, or subjected to use beyond recommended capacities and specifications. Electrical components are subject to respective manufacturers' warranties. All goods returned defective shall be returned prepaid freight to Evolution Power Tools.

Evolution Power Tools reserves the right to repair or replace it with the same or equivalent item. There is no warranty – written or verbal – for consumable accessories such as (following list not exhaustive) blades, cutters, drills, chisels or paddles etc. In no event shall Evolution Power Tools be liable for loss or damage resulting directly or indirectly from the use of our merchandise or from any other cause. Evolution Power Tools is not liable for any costs incurred on such goods or consequential damages.

No officer, employee or agent of Evolution Power Tools is authorized to make oral representations of fitness or to waive any of the foregoing terms of sale and none shall be binding on Evolution Power Tools.

Questions relating to this limited guarantee should be directed to the company's head office, or call the appropriate Helpline number.

SPECIFICATIONS**S42MAG****S28MAG**

MACHINE	METRIC	IMPERIAL	METRIC	IMPERIAL
Motor (UK/EU) 230V - 240V ~ 50Hz	1200W	-	-	-
Motor (UK/EU) 220V - 240V ~ 50HzV	-	-	1200W	-
Motor (UK) 110V ~ 50Hz	1200W	-	1200W	-
Motor (USA) 120V ~ 60Hz	-	10A	-	10A
Number Of Speeds	1	1	1	1
Speed (No Load) - 220-240V	450min ⁻¹	450rpm	480min ⁻¹	480rpm
Speed (No Load) - 110V & 120V	450min ⁻¹	450rpm	450min ⁻¹	450rpm
Insulation Class	1	1	1	1
Power Cord Length	2.5m	8' 2"	2.5m	8' 2"
Weight	12kg	26lb	12kg	26lb
CUTTER CAPACITIES				
Maximum Annular Cutting Capacity	42mm	1-5/8"	28mm	1-1/8"
Maximum Cutting Depth	50mm	2"	50mm	2"
Cutter Shank	19mm	3/4"	19mm	3/4"
Standard Twist Drill Capacity	13mm	1/2"	13mm	1/2"
MAGNET				
Magnetic Adhesion	1300kg f	2860lbs f	1300kg f	2860lbs f
Minimum Plate Thickness	10mm	3/8"	10mm	3/8"
DIMENSIONS				
Magnet Dimension	40 x 90 x 180mm	1-5/8 x 3-1/2 x 7-1/8"	40 x 90 x 180mm	1-5/8 x 3-1/2 x 7-1/8"
Maximum Machine Height	654mm	25-3/4"	650mm	25-5/8"
Minimum Machine Height	420mm	16-1/2"	420mm	16-1/2"
Machine Width	222mm	8-3/4"	200mm	7-7/8"
NOISE & VIBRATION				
Sound Pressure Level L _{PA}	89.40 dB(A) K=3 dB(A)		110V: 91 dB(A) K=3 dB(A) 220-240V: 90.7 dB(A) K=3 dB(A)	
Sound Power Level L _{WA}	102.4 dB(A) K=3 dB(A)		110V: 102 dB(A) K=3 dB(A) 220-240V: 101.7 dB(A) K=3 dB(A)	
Hand Arm Vibration	0.629m/s ² K=1.5m/s ²		110V: 2.41m/s ² K=1.5m/s ² 220-240V: 2.12 m/s ² K=1.5m/s ²	
MODEL NUMBERS				
United Kingdom	230V: 095-0001 110V: 095-0002		230V: 090-0005 110V: 090-0006	
United States	095-0003		090-0007	
Europe	095-0004		090-0008	

Note: The vibration measurement was made under standard conditions in accordance with: EN62841-1: 2015 and UL Std. 62841-1 and CSA Std. C22.2 No. 62841-1

The declared vibration total value has been measured in accordance with a standard test method and may be used for comparing one tool with another.

The declared vibration total value may also be used in a preliminary assessment of exposure.

WARNING: that the noise emissions during actual use of the power tool can differ from the declared values depending on the ways in which the tool is used especially what kind of workpiece is processed; and of the need to identify safety measures to protect the operator that are based on an estimation of exposure in the actual conditions of use (taking account of all parts of the operating cycle such as the times when the tool is switched off and when it is running idle in addition to the trigger time).

VIBRATION

WARNING: When using this machine the operator can be exposed to high levels of vibration transmitted to the hand and arm. It is possible that the operator could develop “Vibration white finger disease” (Raynaud syndrome). This condition can reduce the sensitivity of the hand to temperature as well as producing general numbness. Prolonged or regular users of this machine should monitor the condition of their hands and fingers closely. If any of the symptoms become evident, seek immediate medical advice.

- The measurement and assessment of human exposure to hand-transmitted vibration in the workplace is given in: BS EN62841-1: 2015
- Many factors can influence the actual vibration level during operation e.g. the work surfaces, condition and orientation and the type and condition of the machine being used. Before each use, such factors should be assessed, and where possible, appropriate working practices adopted. Managing these factors can help reduce the effects of vibration:

Handling:

- Handle the machine with care, allowing the machine to do the work.
- Avoid using excessive physical effort on any of the machine’s controls.
- Consider your security and stability, and the orientation of the machine during use.

Work Surface:

- Consider the work surface material; its condition, density, strength, rigidity and orientation.













WARNING: The vibration emission during actual use of the power tool can differ from the declared total value depending on the ways in which the tool is used. The need to identify safety measures and to protect the operator are based on an estimation of exposure in the actual conditions of use (taking account of all parts of the operating cycle, such as the times the tool is switched off, when it is running idle, in addition to trigger time).

LABELS & SYMBOLS

WARNING: Do not operate machine if warning and/or instruction labels are missing or damaged. Contact Evolution Power Tools for replacement labels.

NOTE: All or some of the following symbols may appear in the manual or on the product.

SYMBOL	DESCRIPTION
V	Volts
A	Amperes
Hz	Hertz
Min ⁻¹	Speed
~	Alternating Current
n ₀	No Load Speed

	Eye protection should be worn at all times when using this tool.
	Hard Hat—Head protection should be worn at all times whilst using this tool, to protect from overhead hazards
	Ear protection / Ear defenders should be worn at all times whilst using this tool, this tool exceeds 85dB(A)
	Wear Dust Protection
	Electrical enclosure - risk of electric shock.
	Read and understand the instruction manual - before operating this tool.
	Caution ! / Attention !
	Fuse
	CE certification
	ETL certification Intertek 4006100
	Triman - Waste Collection & Recycling
	WEEE - Waste Electrical and Electronic Equipment This machine should be disposed of as Electrical & Electronic Waste.

INTENDED USE

- This power tool is intended to be used for drilling holes with annular cutters and twist drills in an industrial environment.
- The machine is designed to be held onto a ferrous surface using its

electromagnetic base.

- This power tool should be used in a weather protected environment, and be used with the accessories provided, or Evolution Power Tools recommended accessories only.
- The power tool can be used vertically, horizontally and in an inverted position, provided the magnetic adhesion and work environment allow.

WARNING: To prevent ingress of fluids into the electrical system, cutting paste should be used rather than cutting fluid when using the machine in the inverted position.

PROHIBITED USES

- This power tool should never be used without a ground or protective earth connection.
- This power tool should not be used in a potentially explosive environment.
- This power tool should not be used in a wet or humid environment where water could be drawn into the power tools cooling and ventilation system.
- If the power tool is used in the inverted or horizontal position, cutting fluids should not be used to prevent ingress of fluids into the electrical system. Cutting paste should be used instead.
- This power tool should never be positioned on a workpiece between the electrode and ground of an arc type welder. Damage to the machine will result as the welder will ground through the power tools ground or earth cable.
- This power tool should not be used where the voltage is abnormally lower than the rated voltage, subject to voltage tolerances. Check the power tool rating plate, check the voltage available.

WARNING: Operating on a lower than rated voltage will result in the electro magnet being at reduced power and the machine may become insecure whilst cutting.

WARNING: This machine is not intended for use by persons (including children) with reduced physical, sensory or mental capabilities, or lack of experience and knowledge. Children should be supervised to ensure that they do not have access to, and are not allowed to play with, this machine.

ELECTRICAL SAFETY

This machine is fitted with the correct moulded plug and mains lead for the designated market. If the replacement of the SUPPLY CORD is necessary, this has to be done by the manufacturer or his agent in order to avoid a safety hazard.

OUTDOOR USE

WARNING: For your protection, if this tool is to be used outdoors it should not be exposed to rain, or used in damp locations. Do not place the tool on damp surfaces. Use a clean, dry workbench if available. For added protection use a residual current device (R.C.D.) that will interrupt the supply if the leakage current to earth exceeds 30mA for 30ms. Always check the operation of the residual current device (R.C.D.) before using the machine.

If an extension cable is required it must be a suitable type for use outdoors and so labelled. The manufacturer's instructions should be followed when using an extension cable.

POWER TOOL GENERAL SAFETY INSTRUCTIONS

(These General Power Tool Safety Instructions are as specified in BS EN 62841-1: 2015 & EN ISO 12100: 2010 & UL Std. 62841-1 & CSA Std. C22.2 No. 62841-1)

WARNING: Read all safety warnings and instructions. Failure to follow the warnings and instructions may result in electric shock, fire and/ or serious injury.

Save all warnings and instructions for future reference.

The term "power tool" in the warnings refers

to your mains-operated (corded) power tool or battery-operated (cordless) power tool.

1) General Power Tool Safety Warnings [Work area safety]

a) Keep work area clean and well lit.

Cluttered or dark areas invite accidents.

b) Do not operate power tools in explosive atmospheres, such as in the presence of flammable liquids, gasses or dust. Power tools create sparks which may ignite the dust or fumes.

c) Keep children and bystanders away while operating power tool.

Distractions can cause you to lose control.

2) General Power Tool Safety Warnings [Electrical Safety]

a) Power tool plugs must match the outlet. Never modify the plug in any way. Do not use any adapter plugs with earthed (grounded) power tools.

Unmodified plugs and matching outlets will reduce the risk of electric shock.

b) Avoid body contact with earthed or grounded surfaces, such as pipes, radiators, ranges and refrigerators. There is an increased risk of electric shock if your body is earthed or grounded.

c) Do not expose power tools to rain or wet conditions. Water entering a power tool will increase the risk of electric shock.

d) Do not abuse the cord. Never use the cord for carrying, pulling or unplugging the power tool. Keep cord away from heat, oil, sharp edges or moving parts.

Damaged or entangled cords increase the risk of electric shock.

e) When operating a power tool outdoors, use an extension cord suitable for outdoor use. Use of a cord suitable for outdoor use reduces the risk of electric shock.

f) If operating a power tool in a damp location is unavoidable, use a residual current device (RCD) protected supply. Use of an RCD reduces the risk of electric shock.

3) General Power Tool Safety Warnings [Personal Safety].

a) Stay alert, watch what you are doing and use common sense when operating a power tool. Do not use a power tool while you are tired or under the influence of drugs, alcohol or medication.

A moment of inattention while operating power tools may result in serious personal injury.

b) Use personal protective equipment.

Always wear eye protection. Protective equipment such as dust masks, non-skid safety shoes, hard hat or hearing protection used for appropriate conditions will reduce personal injuries.

c) Prevent unintentional starting. Ensure the switch is in the off position before connecting to power source and or battery pack, picking up or carrying the tool.

Carrying power tools with your finger on the switch or energising the power tools that have the switch on invites accidents.

d) Remove any adjusting key or wrench before turning the power tool on.

A wrench or key left attached to a rotating part of a power tool may result in personal injury.

e) Do not overreach. Keep proper footing and balance at all times. This enables better control of the power tool in unexpected situations.

f) Dress properly. Do not wear loose clothing or jewellery. Keep your hair, clothing and gloves away from moving parts. Loose clothes, jewellery or long hair can be caught in moving parts.

g) If devices are provided for the connection of dust extraction and collection facilities, ensure that these are connected and properly used. Use of dust collection can reduce dust-related hazards.

h) Do not let familiarity gained from frequent use of tools allow you to become complacent and ignore tool safety principles. A careless action can cause severe injury within a fraction of a second.

4) General Power Tool Safety Warnings [Power tool use and care].

a) Do not force the power tool. Use the correct power tool for your application. The correct power tool will do the job better

and safer at a rate for which it was designed.

b) Do not use the power tool if the switch does not turn it on or off. Any power tool that cannot be controlled with the switch is dangerous and must be repaired.

c) Disconnect the power tool from the power source and/or battery pack from the power tool before making any adjustments, changing accessories or storing power tools. Such preventative safety measures reduce the risk of starting the power tool accidentally.

d) Store idle power tools out of the reach of children and do not allow persons unfamiliar with the power tool or these instructions to operate the power tool.

Power tools are dangerous in the hands of untrained users.

e) Maintain power tools. Check for misalignment or binding of moving parts, breakage of moving parts and any other condition that may affect the power tool's operation. If damaged, have the power tool repaired before use. Many accidents are caused by poorly maintained power tools.

f) Keep cutting tools sharp and clean. Properly maintained cutting tools with sharp cutting edges are less likely to bind and are easier to control.

g) Use the power tool, accessories and tool bits etc. in accordance with these instructions, taking into account the working conditions and the work to be performed. Use of the power tool for operations different from those intended could result in a hazardous situation.

h) Keep handles and grasping surfaces dry, clean and free from oil and grease. Slippery handles and grasping surfaces do not allow for safe handling and control of the tool in unexpected situations.

5) General Power Tool Safety Warnings [Service]

a) Have your power tool serviced by a qualified repair person using only identical replacement parts. This will ensure that the safety of the power tool is maintained.

HEALTH ADVICE

WARNING: When using this machine, dust particles may be produced. In some instances, depending on the materials you are working with, this dust can be particularly harmful. If you suspect that paint on the surface of material you wish to cut contains lead, seek professional advice. Lead based paints should only be removed by a professional and you should not attempt to remove it yourself. Once the dust has been deposited on surfaces, hand to mouth contact can result in the ingestion of lead. Exposure to even low levels of lead can cause irreversible brain and nervous system damage. Young and unborn children are particularly vulnerable.

You are advised to consider the risks associated with the materials you are working with and to reduce the risk of exposure. As some materials can produce dust that may be hazardous to your health, we recommend the use of an approved face mask with replaceable filters when using this machine.

You should always:

- Work in a well-ventilated area.
- Work with approved safety equipment, such as dust masks that are specially designed to filter microscopic particles.

WARNING: the operation of any power tool can result in foreign objects being thrown towards your eyes, which could result in severe eye damage. Before beginning power tool operation, always wear safety goggles or safety glasses with side shield or a full face shield where necessary.

ADDITIONAL SAFETY INSTRUCTIONS

WARNING: Mains Power Supply Security. Due to the nature of operation of this machine, it is of the utmost importance to ensure the security and continuity of the mains power supply. Ensure that this machine has a dedicated power supply, and use a lock on device

to ensure that the mains power supply cannot be interrupted or compromised accidentally.

Do not use other appliances on the same power socket, as any variation in voltage caused by other connected appliances could result in the magnet deactivating. Always use the tool on its own dedicated power socket.

Where the power supply is provided by an 'onsite' generator set, ensure that the generator set is reliable and well maintained, and that the fuel tank contains sufficient fuel to allow completion of the task. The addition of warning labels is strongly recommended.

1) TRANSPORTING and HANDLING

Magnetic Drills are heavy machines, care must be taken when transporting and handling.

- When transporting or moving the Magnetic Drill, always use the carrying handle or other carrying aids provided.
- Always ensure that the dovetail slide is in its lowest position and locked in place.
- Do not transport or move the Magnetic Drill with a cutter attached.
- If the coolant feed system is fitted, ensure that the coolant feed tap is in the off position, or the coolant system has been drained.
- If the Magnetic Drill is to be transported in a vehicle ensure that it is laid on its side and is secured to prevent movement.
- Do not transport the Magnetic Drill with the mains cord and plug dragging along the ground.
- Never carry or drag the machine using the mains cord.

Carrying your Magnetic Drill Safety Advice

- Although compact, this Magnetic Drill is heavy. To reduce the risk of back injury, get competent help, if required, whenever you have to lift the drill.
- To reduce the risk of back injury, hold the tool close to your body when lifting. Bend your knees so you can lift with your legs, not your back. Lift by using the

transportation/lifting handle.

- Never carry the Magnetic Drill by the power cord. Carrying the Magnetic Drill by the power cord could cause damage to the insulation or the wire connections resulting in electric shock or fire.
- Before moving the Magnetic Drill tighten the auxiliary slide locking screw to guard against sudden unexpected movement.
- Lock the Drilling Head in its lowest position.

2) BEFORE USING THE MAGNETIC DRILL

- Check the mains cord and plug for any damage. If damaged it must be replaced before use.
- Check the complete machine for any signs of damage. If the machine is damaged it must not be used until it has been repaired.
- Check the security and condition of the guard. This machine must not be used without the guard being fitted.
- Ensure that the feed handles are attached securely.
- Check that the dovetail slide is correctly adjusted and operates smoothly without any binding or excessive sideways movement. The cutting head should not fall freely under its own weight.
- Check the condition of the webbing safety strap and adjustable buckle for any signs of damage or fraying. If damaged it must be replaced.
- Check that the secondary/auxiliary slide is securely locked by the locking lever.

3) ADJUSTING GIBS (Dovetail Slides) FREE PLAY

Before every use, lubricate and adjust as necessary. When adjusting the gib the following procedure must be followed.

- Using the supplied 3mm Hex Key loosen slightly the 3 cap screws. (**Fig 15**) With all 3 cap screws loosened, ensure that the main slide is at the lowest position.
- Using the 2 mm Hex Key supplied turn the lower and middle adjusting screws to eliminate any free movement.
- Move the main slide upwards until its top edge is level with the top of the dovetail slide way. Turn the upper adjusting screw to take up any free movement.

- Operate the crank handle to move the slide up and down. There should be no free play, yet no binding anywhere throughout the range of travel.
- If necessary repeat the above procedure several times to ensure that all free movement has been eliminated and that the machine head moves up and down freely without any binding and without any side to side movement.
- Re-tighten the 3 cap screws when adjustment is complete.

4) COOLANTS and LUBRICANTS

The use of coolants or lubricants will ease the cutting operation and prolong the life of the cutter and the machine.

- When using coolants or lubricants, ensure that they do not run down the mains cord to the mains plug and supply outlet. Do not allow coolants or lubricants to enter the machine's ventilation openings.
- When using the machine in an inverted position or on vertical surfaces use cutting paste instead of a liquid cutting fluid.
- If the machine is to be used to cut materials that create dust, such as cast iron, dust extraction equipment (not supplied) should be used and/or the operator should wear a suitable respiratory protection mask.

5) PREPARATION and SETTING UP

The electromagnet on this machine is designed to adhere to ferrous metallic surfaces only.

WARNING: The electro magnet fitted to this machine is a two stage magnet. With the machine positioned, and the magnet switched 'ON' but the motor switched 'OFF' the magnet is at 50% strength. The magnet only reaches full strength when both the Magnet and Motor switches are in the 'ON' position.

WARNING: The use on any material whose thickness is less than that specified in this Instruction Manual will progressively reduce the magnetic performance, and could result in a potentially dangerous condition arising.

- Always prepare the material surface before attaching the machine.
The material surface must be clean, flat and free from rust, protective coatings, grease or other debris such as chips or swarf from previously drilled holes.
- Always check the surface of the magnetic base ensuring that it is not damaged and is clear of debris such as chippings or swarf from previously drilled holes.
- Never use this machine on a structure where arc welding is taking place. Damage to the machine will result as the welder will ground through the power tools ground or earth cable.

6) DURING CUTTING OPERATIONS

WARNING: The swarf and the slug produced will be hot and sharp.

- When using annular cutters ensure that the slug ejected at the end of the cut will not endanger anyone in the vicinity.
- If working at height some form of collection device for the ejected slug may be necessary.
- Care should be taken with the ejected slug, this will be both hot and sharp, gloves should be worn when handling the slug.
- This power tool can be used on a vertical surface or upside down provided there is sufficient magnetic adhesion, extra care should be taken when drilling vertically or inverted. When using the machine vertically or inverted it is possible hot and sharp swarf or chips may fall. Always wear appropriate personal protective equipment.

7) SAFETY STRAP OR SAFETY CHAIN

WARNING: The electromagnet base on this power tool can deactivate if the power supply is interrupted or suffers an electrical malfunction.

- To prevent possible operator injury, the safety strap or chain supplied should be used at all times to provide extra security in the event of supply failure or electrical malfunction.

Note: When drilling some very large flat, horizontal plates, the fitting of the safety strap or chain may be impossible. Consult the responsible person for guidance.

- The safety strap or chain should be attached to the fixing points provided and checked for security before commencing any and every drilling operation.

GETTING STARTED - UNPACKING

Caution: This packaging contains sharp objects. Take care when unpacking. This machine could require two persons to lift, assemble and move. Remove the machine, together with the accessories supplied from the packaging. Check carefully to ensure that the machine is in good condition and account for all the accessories listed in this manual. Also make sure that all the accessories are complete. If any parts are found to be missing, the machine and its accessories should be returned together in their original packaging to the retailer. Do not throw the packaging away; keep it safe throughout the guarantee period. Dispose of the packaging in an environmentally responsible manner. Recycle if possible. Do not let children play with empty plastic bags due to the risk of suffocation.

ITEMS SUPPLIED

DESCRIPTION	S42MAG	S28MAG
Instruction Manual	✓	✓
Coolant System	✓	✓
Safety Guard & Fixings	✓	✓
Safety Strap	✓	✓
Feed Handles	✓ (x3)	✓ (x3)
Hex Keys	✓ (x4)	✓ (x2)
Chuck with Chuck Key	✓	✓
Carry Case	✓	✓

ADDITIONAL ACCESSORIES

In addition to the accessories supplied with this machine the following accessories are available from Evolution's online shop at www.evolutionpowertools.com or from your local retailer.

Description	Part No
Chuck Adaptor	HTA 47
Chuck & Chuck Key 13mm	HTA 153
Countersink Bit 0-30mm	HTA 030
3 Piece Cutter Kit	
6 Piece Cutter Kit	
Cyclone Cutters	

MACHINE OVERVIEW

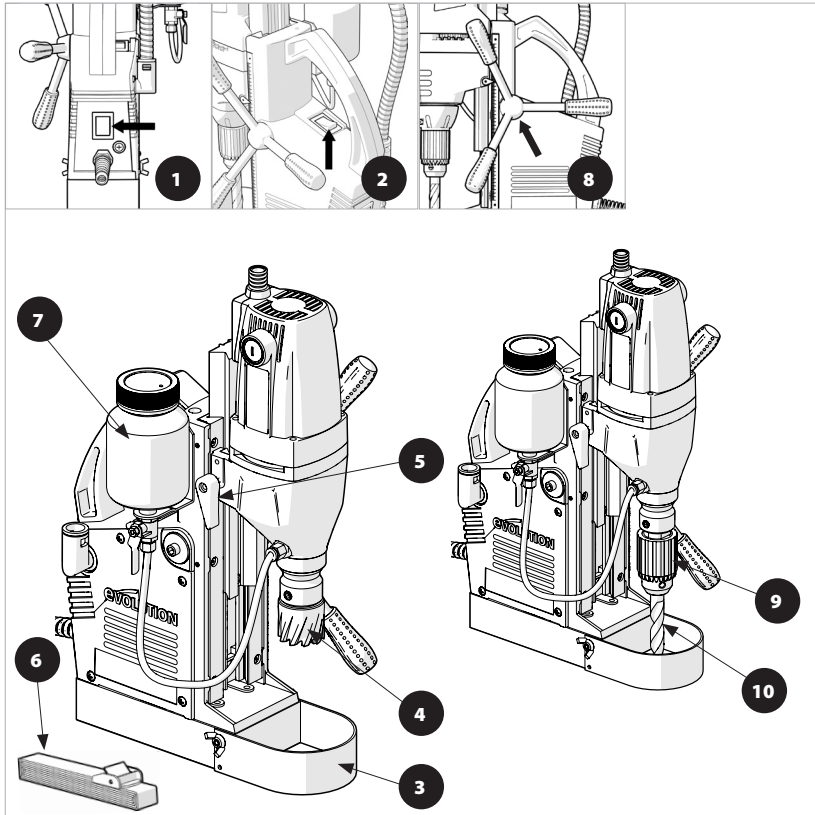

**MACHINE FITTED WITH
ANNULAR CUTTER**

- 1. Magnet On/Off Switch
- 2. Motor On/Off Switch
- 3. Guard
- 4. Annular Cutter (Not included)
- 5. Secondary Slide Locking Lever
- 6. Safety Strap
- 7. Coolant Tank
- 8. Spindle Hub And Feed Handles

**MACHINE FITTED WITH
3 JAW CHUCK**

- 9. 3 Jaw Chuck
- 10. Drill Bit (Not included)

ASSEMBLY AND PREPARATION

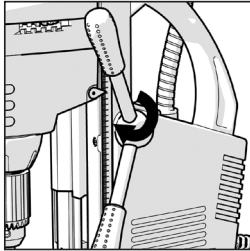

Fig. 1

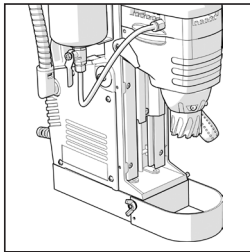

Fig. 2

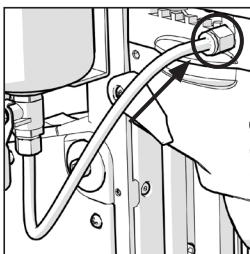

Fig. 3a

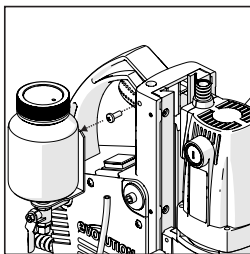

Fig. 3

WARNING: Mag Drills must not be connected to a power source until all assembly and preparation has been completed and a safety check carried out. Evolution Mag Drills should only be used on non-coated Mild Steel which is free from paint or loose rust etc.

Remove the machine from the case and check that all accessories are present and correct.

WARNING: All Magnetic Drilling machines are heavy. Enlist competent help when lifting these machines.

- Place the machine onto a clean, sturdy work surface.
- Attach the three handles into the spindle hub ensuring that they are fully seated. **(Fig. 1)**
- Attach the Safety Guard and secure in place using the supplied fixing screws. **(Fig. 2)**
- Attach the coolant/lubrication bottle to its service position. Use the tapped hole located at the top left of the machines casing and the Ø6 screw (provided). **(Fig. 3)**
- Insert the 'free' end of the supply tube into the 'quick connector'.

Note: To release the delivery tube from the quick connector **(Abb.3a)** push the collar towards the brass union and withdraw the delivery tube.

Note: For some operations it may be convenient to remove the coolant/lubricant bottle and supply tube and use alternative methods of coolant or lubricant application.

TESTING - All Evolution Magnetic Drilling Machines

WARNING: All Evolution Magnetic Drilling machines have Class 1 insulation and must be earthed. Any power socket that this machine is connected to must be grounded to earth. Ensure that both operating switches are in the 'OFF' position before connecting the power cord to the socket.

WARNING: The power cord assembly is a custom terminated one. Replacement should only be carried out by a qualified technician. Use only replacement parts recommended by Evolution Power Tools.

WARNING: Do not perform any testing with a cutter or drill installed in the machine.

- Place the machine onto a piece of clean 10 mm thick mild steel plate that is larger than the magnetic base of the machine.
- Connect the plug into a mains supply outlet and switch on the socket (UK only).
- Operate the rocker switch on the machines switch panel to energise the magnet. **(Fig. 4)**

NOTE: S28MAG is fitted with a 10 Amp 230v (5 x 20mm) Surge Fuse. This is located in a fuse holder found in the machines switch panel. **(Fig. 5)** If the machine fails to operate, check the fuse. If it has 'blown' have the cause investigated by a competent technician. Replace it with an identical type when satisfied that the machine is fault free.

- Check that the machine is firmly attached to the Mild Steel plate.
- Operate the machines On/Off rocker switch **(Fig. 6)** to switch 'On' or to switch 'Off' the machines motor.
- Allow the motor to run for a few seconds to check for any unusual noise or vibration.

WARNING: Do not use the machine if any vibration or unusual noises are evident or if the magnetic adhesion is questionable. Have the machine serviced and checked by a qualified technician, or if under warranty refer to the warrantee agreement.

- When all testing has been completed, turn the machine 'off.'

INSTALLING AN ANNULAR CUTTER - All Evolution Machines

Select a suitable cutter for the required task. Check that the cutter is sharp and is not damaged in any way. Damaged or 'dull' cutters should not be used.

WARNING: Annular cutters are very sharp. It is recommended that the operator wears protective gloves whilst handling a cutter during installation or removal.

- Insert the pilot pin into the cutter ensuring that it slides through the bore in the cutter smoothly. **(Fig.7)**
- Raise the machines Cutting Head (the Motor/Gearbox assembly) to its highest position.
- Check that the cutter securing grub screws located in the end of the spindle are not protruding into the spindle bore. (S42MAG - **Fig.8.**) (S28MAG - **Fig.9)**
- Align the two 'flats' machined on the cutters shaft with the grub screws in the spindle.
- Insert the cutter shaft into the bore of the spindle.
- Start to tighten one of the grub screws and at the same time slightly rotate the cutter backwards and forwards until the grub screw is fully tightened. This will ensure that the grub screw is located squarely onto the flat, preventing the cutter from becoming loose.
- Tighten the remaining grub screw.

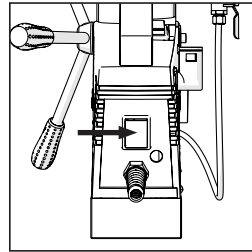

Fig. 4

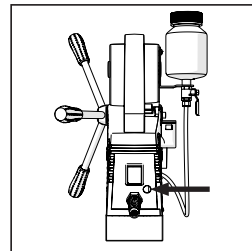

Fig. 5

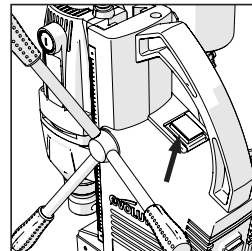

Fig. 6

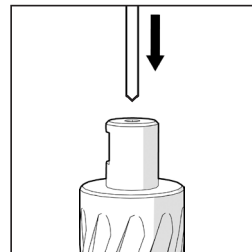

Fig. 7

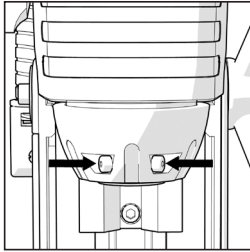

Fig. 8

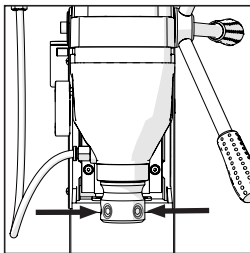

Fig. 9

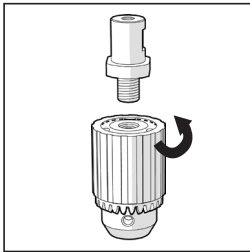

Fig. 10

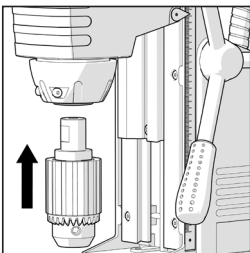

Fig. 11

INSTALLING A 3 JAW CHUCK

(UK Market only)

A three (3) jaw chuck (part HTA 153) can be fitted into the drive spindle of S28MAG enabling the machine to take standard parallel shank twist drills up to Ø13mm (Ø1/2in).

WARNING: Ensure that the machine is disconnected from the mains power supply when installing the 3 jaw chuck.

To fit the chuck:

- Screw the 3 jawed chuck into the threaded bore of the chuck adaptor. (Fig. 10)
- Align the two (2) 'flats' machined on the chuck adaptor with the grub screws in the spindle. (Fig. 11)
- Insert the chuck adaptor into the bore of the spindle.
- Start to tighten one of the grub screws and at the same time slightly rotate the adaptor backwards and forwards until the grub screw is fully tightened. This will ensure that the grub screw is located squarely onto the flat, preventing the chuck adaptor from becoming loose.
- Tighten the remaining grub screw.

TO INSTALL AND REMOVE A DRILL BIT

Hold the new drill bit with your thumb and index finger, then insert it into the chuck. Twist the chuck to tighten the drill bit into place. If your chuck has a key, insert the key and turn it tighten the drill bit in place, then turn the opposite direction to slide the drill bit out.

SETTING UP

(PRIOR TO COMMENCING CUTTING OPERATIONS)

WARNING: Operators should read the section on intended and prohibited uses of these machines. Only trained and experienced operatives should use these machines.

Magnetic Drilling machines should only be used for hole boring/drilling whilst attached to the workpiece by the electromagnetic base.

WARNING: MagDrills must only be used if the electromagnet is in full working order and exerts sufficient grip on a correctly prepared workpiece.

Extra vigilance should be exercised if the machine is to be used on a surface which is inclined from the horizontal.

COOLANT / LUBRICANT DELIVERY

Note: It is recommended that a Soluble Oil is used as other coolants/lubricants may have a high viscosity and may not flow easily to the cutter.

WARNING: In the event of power disruption or failure the safety chain/strap ensures that the machine remains in place attached to the workpiece. **(Fig12)** As a crucial safety feature it must be securely attached to both the machine and to the workpiece. BEFORE beginning cutting operations the strap or chain must be correctly fitted, preferably passing through the machines carrying handle. The safety chain/strap should NOT be used as an alternative to the magnet for clamping purposes.

To ensure Coolant/Lubricant flow:

- Gently squeeze the Coolant/Lubricant bottle to force the Coolant/Lubricant through to the cutter.
- Lower the Cutting Head towards the workpiece until the cutter teeth touch the workpiece, and the pilot pin has been pushed up into the cutter.
- Raise the Cutting Head.
- Repeat this process until coolant/lubricant fluid is flowing freely onto the workpiece.
- Adjust the ON/OFF Tap to give the fluid flow required

Note: Sometimes the position of the machine on the workpiece (or when a 3 jaw chuck is fitted) makes delivery of coolant/lubricant impossible. If this is the case a suitable 'cutting compound' can be applied directly to the workpiece before cutting operations begin. The compound may need to be replenished during the cutting process.

WARNING: Only replenish cutting compound after the motor has been switched 'OFF' and it and the cutter are completely stationary.

ANTI STALL TECHNOLOGY

This machine is fitted with the latest Anti Stall Technology (AST).

If the cutting forces result in the motor stalling, the electronics will switch off the motor, preventing burnout. The magnet however will remain energised holding the machine safely in position.

To reset after AST activation:

- Set the motor switch to the OFF position.
- Back-off (withdraw) the cutter from the material.
- Wait 3-5 seconds before restarting the motor. Set the motor switch to ON position.

Note: If after AST activation, or at any other time during operations the machine fails to (re)start, or there is no magnetic adhesion, check the 10 amp Surge Fuse. Refer to Testing.

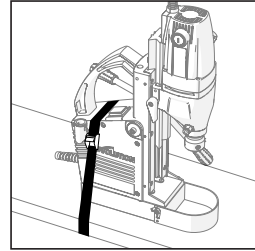

Fig. 12

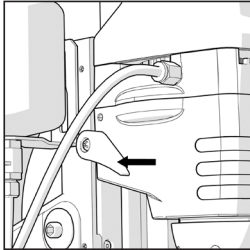

Fig. 13

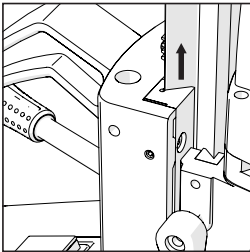

Fig. 14

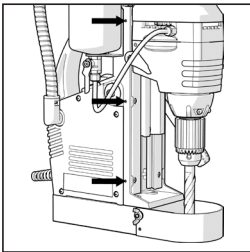

Fig. 15

MAKING A CUT

Note: The Cutting Head of S28MAG machine can be repositioned and locked anywhere along the length of machines dovetail slide. Repositioning may be necessary to accommodate the longer overall length of the Cutting Head especially when fitted with a three (3) jawed chuck and twist drill.

GENERAL GUIDANCE

Evolution Power Tools has no control over the way its machinery may be used. The following is offered as general (but not exhaustive or definitive) advice on the safe operation of MagDrill machines.

WARNING: Securely lock the Cutting Head onto the machines slide **BEFORE** commencing cutting operations.

- Lock the Cutting Head onto the dovetail slide in the required position. The locking lever is located on the left hand (LH) lower gearbox casing. (Fig. 13)
- Correctly position the machine on the workpiece, with the electromagnet energised and the safety chain/strap securely in place.
- Check for sufficient coolant/lubricant flow at the cutter.
- Start the motor by operating the 'On/Off' rocker switch.
- Using the feed handles slowly lower the Cutting Head until the cutter (or drill) makes contact with the workpiece.
- Continue to apply only sufficient gentle pressure to allow the cutter to cut freely through the workpiece.
- Depending upon the thickness of the workpiece periodically raise the cutter and clear any 'swarf' build up before to continuing the cut.

WARNING: Only clear 'swarf' from a cut using a suitable tool (small brush or similar) with the Cutting Head raised and the spindle, cutter and motor completely stationary. Take all H&S precautions that may be necessary.

WARNING: On completion of the cut the pilot pin should eject the (waste) material 'slug'. This slug could be very hot with very sharp edges. Employ all necessary H&S procedures to safely deal with any ejected slug(s), and use protective gloves if the slug(s) require handling.

If the slug fails to be ejected from the cutter, this could be caused by the slug becoming 'twisted' inside the cutter. To release the slug, lower the cutter onto a flat area of the workpiece. This will 'square-up' the slug and allow it to be ejected.

MAINTENANCE

WARNING: Any maintenance must be carried out with the machine switched off and disconnected from the mains/battery power supply.

Check that all safety features and guards are operating correctly on a regular basis. Only use this machine if all guards/safety features are fully operational.

All motor bearings in this machine are lubricated for life. No further lubrication is required.

Use a clean, slightly damp cloth to clean the plastic parts of the machine. Do not use solvents or similar products which could damage the plastic parts.

WARNING: Do not attempt to clean by inserting pointed objects through openings in the machines casings etc. The machine's air vents should be cleaned using compressed dry air.

Excessive sparking may indicate the presence of dirt in the motor or worn out carbon brushes.

If this is suspected have the machine serviced and the brushes replaced by a qualified technician.

If the supply cord of this power tool is damaged, it must be replaced by a specially prepared supply cord available through the service organization.

ADJUSTING GIBS (Dovetail Gibs Slides)

WARNING: Only attempt this procedure with the machine disconnected from the mains power supply.

Note: S28MAG has two Gibs (**Fig. 14**) one of which is adjustable.

Before every use:

- Check and lubricate the Gibs.
- Check the movement of the Cutting Head. This must be smooth, exhibit no free play and no binding anywhere along its range of travel.

WARNING: The Cutting Head must not be able to slide downwards under its own weight. It should only move when the feed handles are turned.

To adjust the Gib:

Position the Cutting Head so that the top edge of the dovetail slide is level with the top edge of the machines Gibs.

Note: The locking and adjusting screws are located along the Left Hand edge of the machines main slide. (**Fig. 15**)

- Use hex key (supplied) to loosen slightly the locking screws which lock the adjustable Gib in place.
- Use a hex key (supplied) and starting with the lowest adjusting screw, turn the screw clockwise or counter- clockwise as required.
- Work upwards adjusting each of the screws accordingly.

WARNING: There must be no free play, sideways movement (wobble) or binding detectable anywhere throughout the Cutting Heads range of travel.

- Repeat the procedure several times. Ensure that any free play, sideways movement or wobble during travel has been completely eliminated.
- When adjustment has been successfully accomplished, retighten the locking screws.

Recheck the movement of the Cutting Head by operating the feed handles.

ENVIRONMENTAL PROTECTION

Waste electrical products should not be disposed of with household waste. Please recycle where facilities exist. Check with your local authority or retailer for recycling advice.

Do not dispose of electrical appliances in the household waste. According to European Directive 2012/19 / EU on waste electrical and electronic equipment and transposition into national law, used electrical appliances must be collected separately and recycled in an environmentally sound manner.

Recycling alternative to the return request: As an alternative, the owner of the electrical appliance is obliged to cooperate with the proper utilization in case of a property assignment instead of return. For this purpose, the old device can also be left to a take-back point, which carries out a disposal within the meaning of the National Closed Substance Cycle and Waste Management Act. Accessories and accessories without electrical components attached to old appliances are not included.



DECLARATION OF CONFORMITY



The manufacturer of the product covered by this Declaration is:

UK: Evolution Power Tools Ltd. Venture One, Longacre Close, Holbrook Industrial Estate, Sheffield, S20 3FR.

FR: Evolution Power Tools SAS. 61 Avenue Lafontaine, 33560, Carbon-Blanc, Bordeaux, France.

The manufacturer hereby declares that the machine as detailed in this declaration fulfils all the relevant provisions of the Machinery Directive and other appropriate directives as detailed below. The manufacturer further declares that the machine as detailed in this declaration, where applicable, fulfils the relevant provisions of the Essential Health and Safety requirements.

The Directives covered by this Declaration are as detailed below:

2006/42/EC.	Machinery Directive.
2014/30/EU.	Electromagnetic Compatibility Directive.
2011/65/EU. & 2015/863/EU.	The Restriction of the Use of Certain Hazardous Substances in Electrical Equipment (RoHS) Directive.
2002/96/EC as amended by 2003/108/EC	The Waste Electrical and Electronic Equipment (WEEE) Directive.

And is in conformity with the applicable requirements of the following documents

EN 62841-1:2015 • EN ISO 12100:2010 • EN 55014-1: 2017 • EN 55014-2: 2015 • EN61000-3-2 :2014 • EN61000-3-3: 2013 • EN 50581:2012

Product Details

Description	S28MAG 28mm Magnetic Drill
Model Number	220-240V: 090-0005 / 090-0008 / 110V: 090-0006
Description	S42MAG 42mm Magnetic Drill
Model Number	230-240V: 095-0001 / 095-0004 / 110V: 095-0002
Brand	EVOLUTION
Voltage	S28MAG 110V / 220-240V ~ 50Hz S42MAG 110V / 230-240V ~ 50Hz
Input	1200W

The technical documentation required to demonstrate that the product meets the requirements of directive has been compiled and is available for inspection by the relevant enforcement authorities, and verifies that our technical file contains the documents listed above and that they are the correct standards for the product as detailed above.

Name and address of technical documentation holder.

Signed:  Print: Barry Bloomer, CEO
Date: 01/10/19

UK: Evolution Power Tools Ltd. Venture One, Longacre Close, Holbrook Industrial Estate, Sheffield, S20 3FR.

FR: Evolution Power Tools SAS. 61 Avenue Lafontaine, 33560, Carbon-Blanc, Bordeaux, France.

evOLUTION®

www.evolutionpowertools.com

UK

Evolution Power Tools Ltd
Venture One
Longacre Close
Holbrook Industrial Estate
Sheffield
S20 3FR

+44 (0)114 251 1022

US

Evolution Power Tools LLC
8363 Research Drive
Davenport
Iowa
52806

+1 866-EVO-TOOL

EU

Evolution Power Tools SAS
61 Avenue Lafontaine
33560
Carbon-Blanc
Bordeaux

+ 33 (0)5 57 30 61 89

Discover Evolution Power Tools

Visit: www.evolutionpowertools.com or download the QR Reader App on your smart phone and scan the QR code (Right).

